

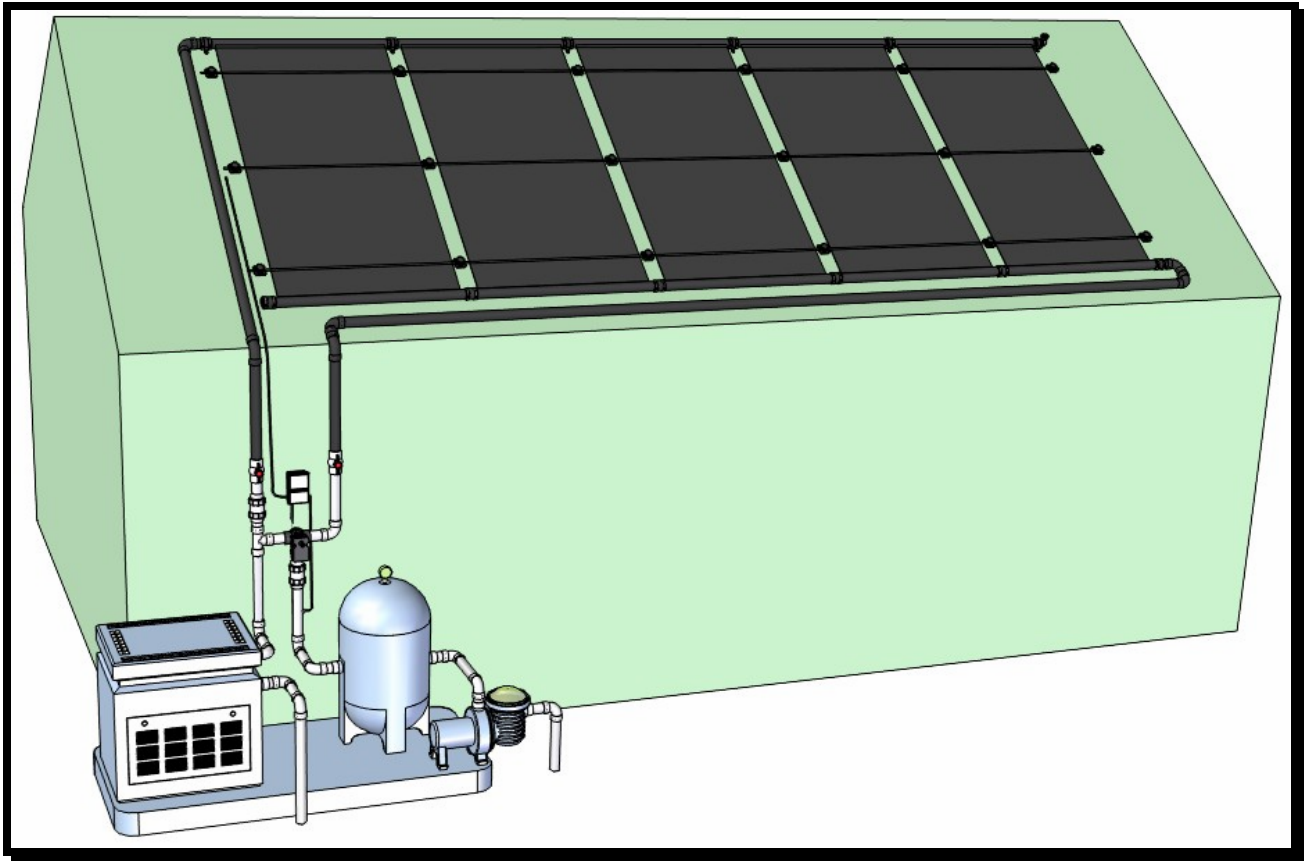

[www.EagleSunSystem.com](http://www.EagleSunSystem.com)

# Solar Pool Heating System Installation Manual



**Read the complete manual before beginning the installation**

## 1. Sizing the System

Visit [www.eaglesunsystem.com](http://www.eaglesunsystem.com) to size the system using the sizing calculator. Panels are available in 4'x8', 4'x10', and 4'x12'. Use larger panels where possible to lower the cost per square foot.

## 2. Where to Install

Determine the roof(s) where the panels will be installed. In the northern hemisphere, the panels should face (in the order of efficiency) south, flat, west or east. Panels may never face north. Panels must be mounted at a minimum angle of 15° for proper drainage. In tropic and sub-tropic climates, the panels may be installed on flat roofs, but in the event of freezing conditions, the water

from the pump must be circulated through the system to prevent panel damage. Most roof surfaces are acceptable for installation including shingle, barrel tile, flat tile, metal, cedar shake, built-up gravel and modified roof systems. The system can also be installed on aluminum or wood ground mounted rack system. For more information on rack or flat roof installations, consult our technical support team.

## 3. Verify Space Requirements

Determine the available area on the roof(s) for the installation. Panels are 48" wide with a 3" gap between absorbers for mounting, totaling 51". Panels are placed next to each other in a row; each panel requires 51"

horizontally (i.e. 7 - 4'x10' panels would be 357" horizontal by 120" vertical.) Panel Rows may be *split* to circumvent large obstacles, to install one row above another row, or to install on separate roofs. Each split requires a "Split Kit." Panels may be spaced around small vents up to 5" without a "Split Kit" provided they fall between panels by using a 6" rubber connector. Each Row requires a minimum of 3" on all sides to allow for feed and return plumbing. See the chart below for typical system space requirements (the Overall Length includes the 3" on each side.)

	Total Length		Total Length
3 Panels	13ft 3in	8 Panels	34ft 6in
4 Panels	17ft 6in	9 Panels	38ft 9in
5 Panels	21ft 9in	10 Panels	43ft
6 Panels	26ft	11 Panels	47ft 3in
7 Panels	30ft 3in	12 Panels	51ft 6in

#### 4. Typical Panel & Plumbing Layouts

Do not use more than 12 panels in any row. Feed the water into the **BOTTOM** corner and return from the opposite top corner, Figure 1. **Note:** Design plumbing layout to have the shortest possible return line to reduce heat losses. For larger systems, split the panels into several rows, Figure 2. Never use "Same End Return", Figure 3, because of reduced efficiency at the opposite end panels. All bottom headers and feed plumbing should allow for gravity drain. In tropic or sub-tropic climates, the panels and plumbing may be level; in northern climates, they must be installed with a 1/4" per foot slope towards the feed. All return lines from multiple panel rows must meet at the highest point of the system.

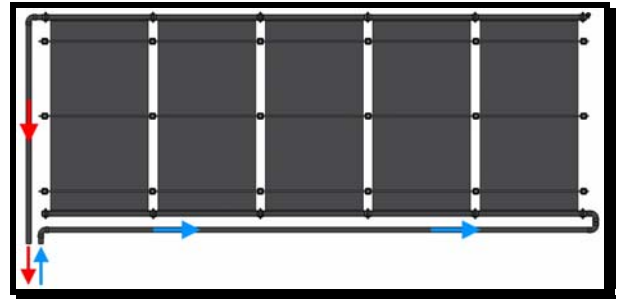

1. Reverse End Return

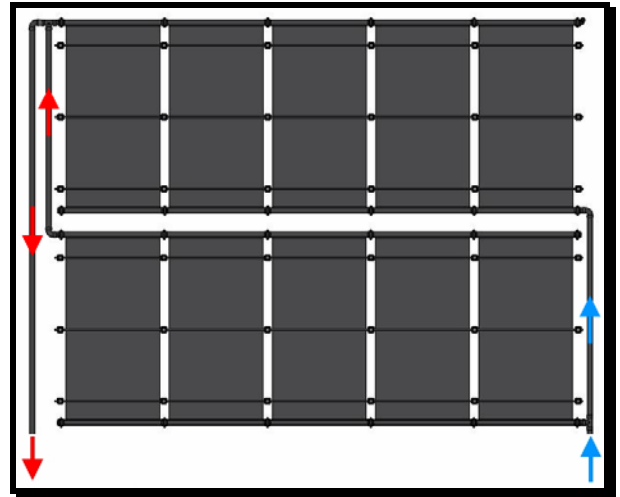

2. Double Row

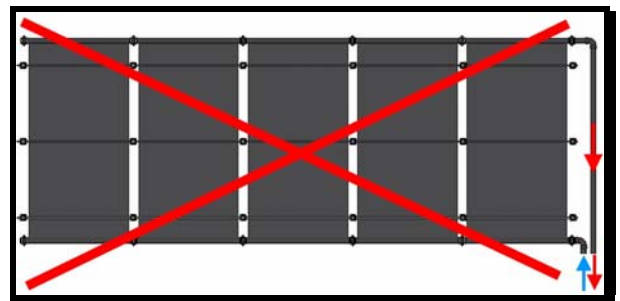

3. Same End Return

## 5. Panel Installation

The following procedure assumes a shingle roof; for other roof types including flat roofs, see Section 11 for Special Roof Requirements

### Step 1

Establish a horizontal chalk line across the roof for the location of the top of the system. This line must have 3/4" clearance above and below it for mounting the Header Clip on a flat surface. For tile roofs, the line should be approximately 2" above the bottom of the tile.

**Note:** For seasonal climates, this line must have a 1/4" per foot slope towards the feed line to allow for drainage and winterization. Then drop a vertical line (90° to the horizontal line) at the left or right end of the installation to locate the first panel. Allow a minimum of 3" on all sides of the panel row for piping. Inspect the roof for any sharp projections that may damage the panels.

### Step 2

Lay out the system before securing any panels. Begin installing the panels on the left working right towards the opposite end. The panels can be installed with either side up, and should be flipped after five years to lengthen their life.

### Step 3

Lay the top header approximately 1 1/4" below the horizontal chalk line. Using the parts from the Panel Kit, install a 3" Rubber Coupling on the top right and bottom right header outlet. Slide a Hose Clamp over each Rubber Coupling and position it over the groove in the header. Rotate the head of each clamp facing up for easy access, shown in Figure 4. Then tighten until snug.

### Step 4

Slide another Hose Clamp over the top and bottom Rubber Coupling. Position the next panel to the right of the first panel, and insert the header outlet into the top and bottom Rubber Coupling of the first panel. Position each Hose Clamp over the groove of the second panel; facing up for easy access. Then tighten until snug. The top and bottom should resemble Figure 5 when finished. If the roof is not too steep for the panels to slide, you may continue connecting panels following Step 3 then Step 4; otherwise move to Step 5.

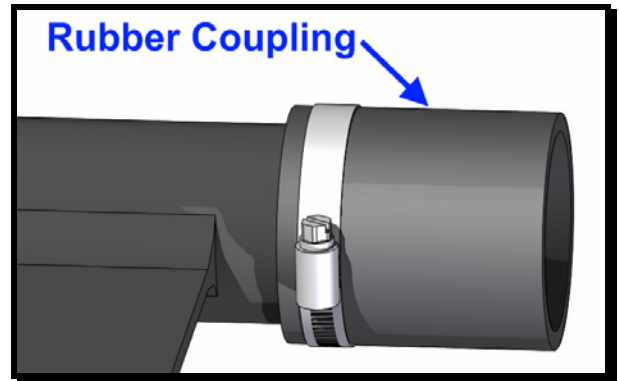

4. Rubber Coupling

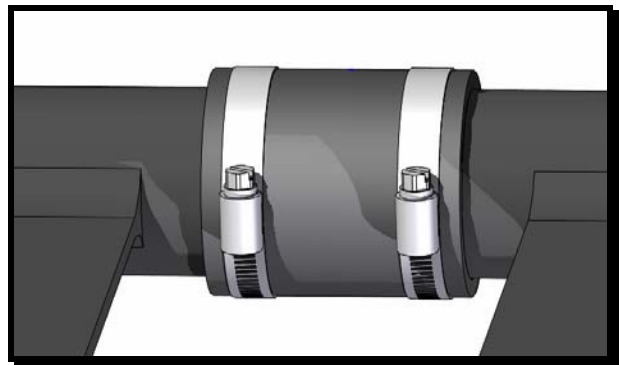

5. Rubber Coupling Installed

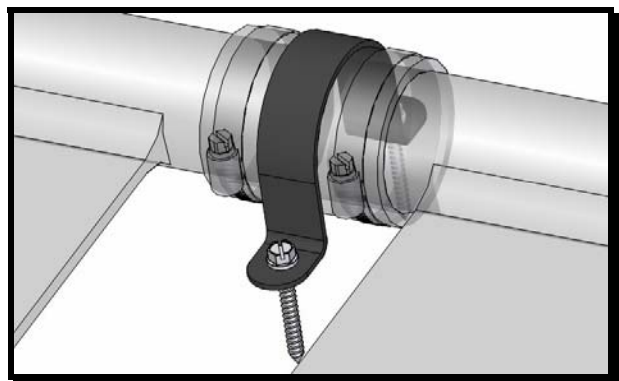

6. U-Shaped Bracket

**Step 5**

Verify that the panels are in position (the top edge of the header should be parallel to the horizontal line; the left edge of the very first panel should be on the vertical line). Place a U-Shaped Bracket over the upper Rubber Coupling and mark the roof where the Hex Screw will penetrate. Remove the U-Shaped Bracket and apply a generous amount of sealant to the marked areas on the roof. Return the U-Shaped Bracket. Using a drill and a 3/8" nut driver, drive two Stainless 3/8 Hex Screws through the holes of the Bracket and into the roof. **Note:** The U-Shaped Bracket should be tightly secured but be sure not to over tighten the screws and strip the wood. When installed it should resemble Figure 6. Finally, apply sealant around the head of the screws.

**Note:** The bottom headers are NOT secured with U-Shaped Brackets to allow for expansion. Continue with Step 4 and Step 5 until all panels in the row are installed.

**Step 6**

Install a Rubber Coupling on the four outside remaining header corners using the Hose Clamps. On the feed and return corners, insert the Pipe to Panel Adapters, seen in Figure 7, into the Rubber Coupling using the end that resembles a header outlet. Secure with a Hose Clamp. On the upper remaining corner, insert the vacuum breaker assembly, Figure 8, and secure with a Hose Clamp. On the bottom remaining corner, insert an End Cap and secure with a Hose Clamp, Figure 9. Secure the final two top Rubber Couplings to the roof with U-Shaped Brackets just as you did in Step 5.

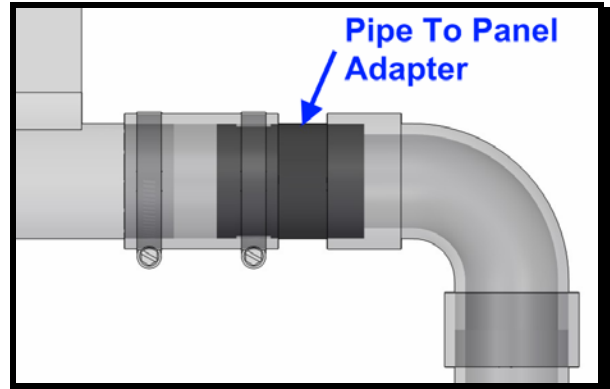

7. Pipe to Panel Adapter

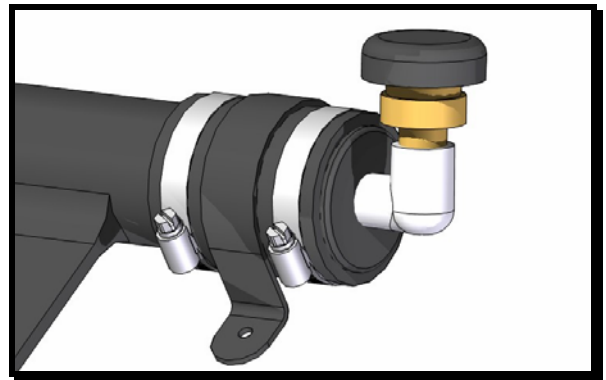

8. Vacuum Breaker Assembly

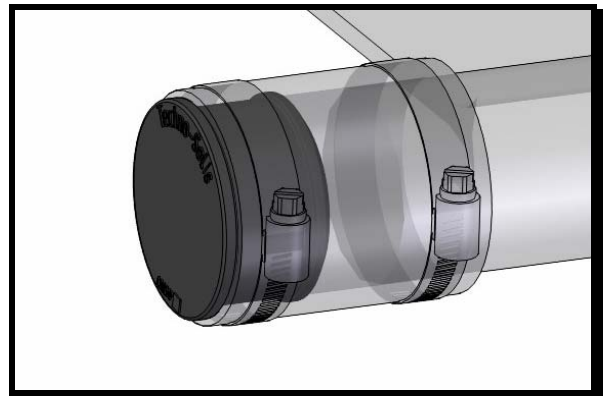

9. End Cap

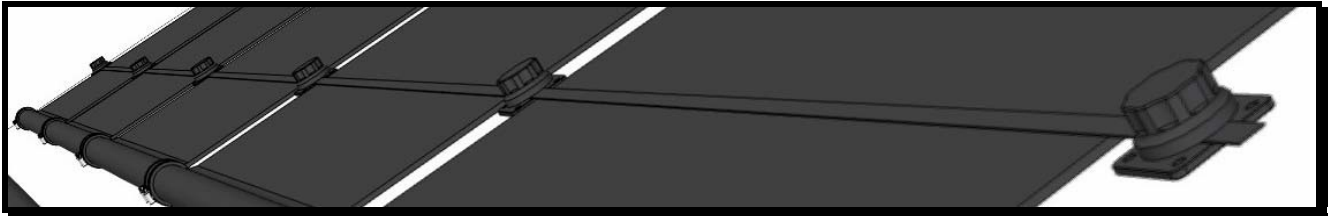

**10. Hold Down Straps**

**Step 7**

The Hold Down Straps may now be installed. A minimum of 3 straps is required. In high wind areas increase the number of straps per panel row, particularly for the longer panels.

The bottom Strap is always located 12" above the bottom header. The remaining Strap(s) are equally spaced between the bottom Strap and the top header. You may want to use a chalk line to mark this spacing before you install the panels by measuring down from the top horizontal line; or use the shingle lines as a guide.

Install SuperClips along the marked lines between all panels and at the ends of the row.

To install a SuperClip, apply a generous amount of sealant to the base of the clip. Place the base on the marked line and secure with a Stainless 3/8 Hex Screw through the center hole of the base, Figure 11. **Note:** The SuperClip base should be tightly secured but be sure NOT to over tighten the screw and strip the wood. In high wind areas the base can be fastened in the four corners in addition to the center.

Lay strap across the SuperClip base at the left end of the row. Screw on SuperClip cap firmly. Stretch the strap across all the panels to the right and screw on the last SuperClip cap firmly while the strap is under tension. Now working from the center towards the ends of the row, screw each cap on firmly.

After the system is installed for several weeks or even months the Strap may need to be re-tensioned due to expansion of the strap in warmer weather.

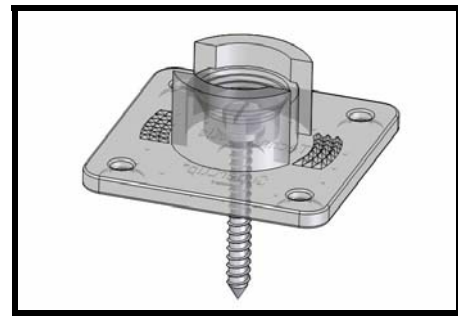

**11. SuperClip Base**

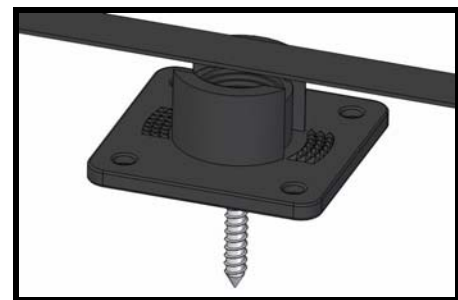

**12. Tensioned Strap**

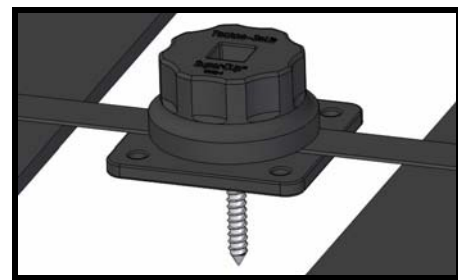

**13. SuperClip Installed**



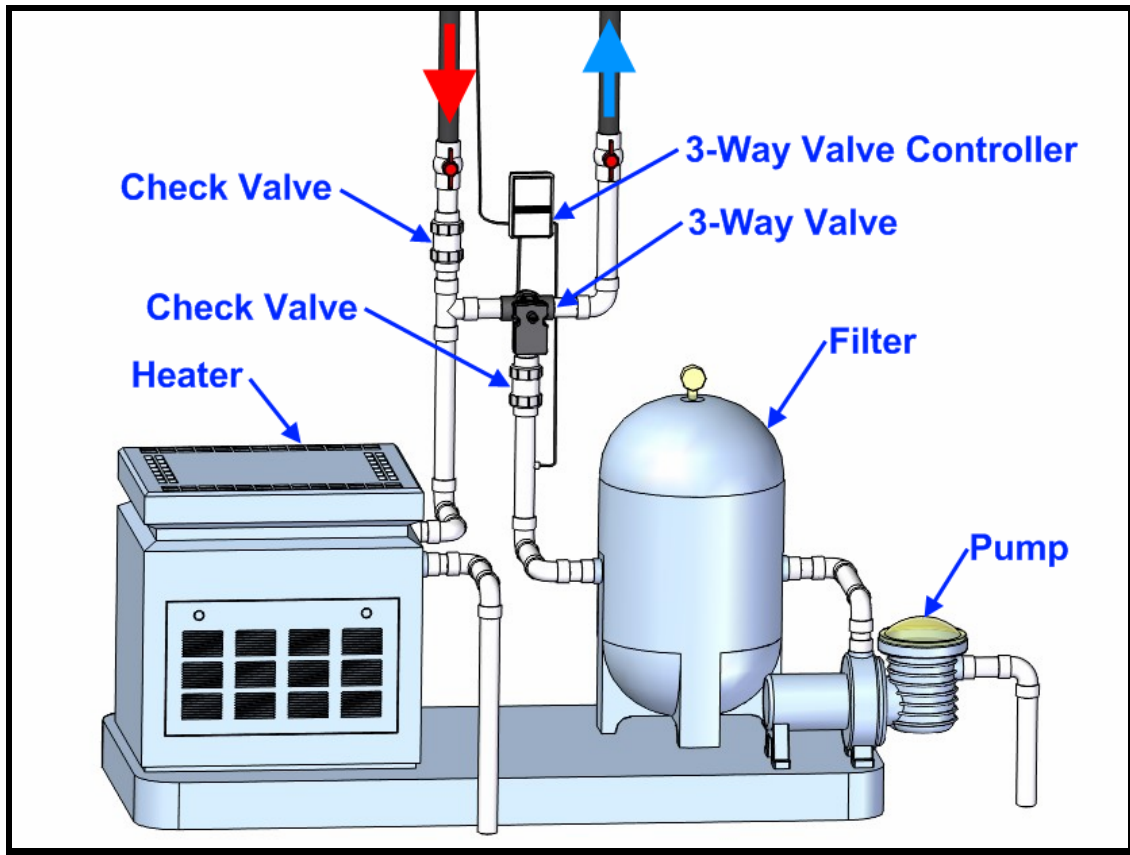

14. Bottom End Plumbing

## 6. Bottom End Plumbing

A typical plumbing layout is in Figure 14. The tie-in for the solar plumbing is always down stream of the filter. You may use 1½" pvc pipe for the bottom end plumbing; however, you should use 2" pvc pipe where possible. 2" pvc pipe is recommended above the 3-way and tee. Always use pvc cleaner on all pipe ends and fitting sockets, immediately inserting with a twisting motion. Hold together for at least 30 seconds. Follow the instructions on the cleaner and glue can for proper use. Determine the layout of all the valves and fittings before proceeding. Cut the line after the filter in an area with enough clearance for the new fittings. Install a check valve between the filter and the 3-way valve, with the flow pointing away from the filter (the cone inside the check valve will be facing towards the filter.) Be certain not to allow glue to seal the cone inside the check valve. Typically the 3-way is mounted against the wall of the building

approximately 3' to 4' off the ground with the side outlet facing right and the inlet facing down. Use a 2½" galvanized pipe clamp over the bottom inlet of the valve to secure it to the wall with screws. Plumb into the "inlet" of the 3-way valve from the check valve. The plumbing then continues up the wall, around the eave and onto the roof feeding the solar panels. The side outlet of the 3-way valve connects to the side outlet of the 2" tee. The return from the solar connects to the top of the tee. The bottom of the tee returns to the line going to the pool jets. Install a check valve on the solar return line above the tee, with the direction of flow going into the tee. Most accessories including auxiliary heaters, chlorine feeders, Pool cleaner pumps should be on the return line after the tee. Automatic pool cleaner pumps must be run at night when the solar is off or during the day only after the solar is already running. Failure to do so may result in a burnt-out cleaner pump.



## 7. Pipe Layout

Use 2" Schedule 40 PVC plastic piping between the bottom end plumbing and the panels. White pipe is recommended because of its excellent outdoor life. The pipe may be painted with a good outdoor paint to match the structure or roof. 1½" pipe may be used on splits between panel rows. All plumbing should allow for gravity drain. In tropic or sub-tropic climates, the panels and plumbing may be level; in northern climates, they must be installed with a ¼" per foot slope towards the pool equipment. The panels should gravity drain back to the pool. If it is not possible to route plumbing to allow for panel drainage, a manual drain valve or line should be installed, or the end plugs may be removed to drain panels. Support all pipes every 4' using 2½" Galvanized Pipe Clamps.

## 8. Flow Rate

The sizing calculations made to determine the number of panels to install must be matched to the flow rate from the pool pump, to operate at maximum efficiency. The ideal flow of water per panel is 3 to 5 gallons per minute. The acceptable range is from 3 to 8 gpm per panel. The total gpm flow rate supplied by the pool pump is divided by the number of panels installed to determine this figure. The gpm rating of a pool pump (as indicated on the pump or in the operating manual) will not be its actual output because of the pressure drop due to piping, filter, fittings, and the panels (only when panels are on.) The actual output must be measured by an in-line flow meter or calculated from the pump's efficiency curve. (As the pressure drop increases gpm decreases.) The gpm rate can also be estimated using the pump rating or by consulting the manufacturer. If there is inadequate flow, reducing the number of elbows or using 2 - 45° elbows instead of 90° elbows will reduce friction loss and increase flow. A larger pump (or upgrading the pump motor and impeller) may be required if the flow is below 3 gpm per panel. A simple test to insure that the panels have enough flow is to feel the surface of the panels on a sunny day; it should feel cool to the touch (the heat is being absorbed into the water). If there is too much flow, throttle the 3-way valve towards the bypass to divert additional flow; or install a bypass line across the feed and return lines with a ball valve for adjusting and bypassing flow. A properly sized pool pump and filtration system will circulate the entire volume of pool water once each day; typically in a 8 to 10 hour cycle. Panel sizing is

based on circulating the entire volume of pool water through the panels once each "solar" day. If the filtration system is under sized or can not be extended to run 8 hours per day, a booster pump will be required.

## 9. Startup & Testing

Consult the owner's manual for complete startup procedure. After system is filled with water, check all fittings, hose couplings and panels for leaks. Set the time clock to operate during the solar day, typically 9am to 5pm. Feel the surface of each panel to ensure proper flow; as the pool water flows through it on startup it will cool to the temperature of the pool water. Check for air bubbles from the pool jets.

## 10. Correcting Problems

**Problem:** Air bubbles coming out of the pool jets. This condition results in poor heat transfer, and should be corrected.

**Solution:** First, check the pool pump basket for air bubbles. If the basket is not completely clear of bubbles, there is a good chance that there is a suction leak between the pump and the pool. Check the skimmer to insure the water is at the proper level. Lubricate the basket lid o-ring (consult the pump instructions.) There may be a suction leak between the pump and the pool, or in the pump internal gaskets. This may require a professional to service. Tighten the stainless hose clamps on each rubber coupling. Next try reversing the location of the vacuum breaker valve and end plug on the solar panels. On some systems, the water flows down from the panels faster than the pump will supply it. This allows air to draw in at the rubber connectors. First try tightening the hose clamps; next install a ball valve in the return line from the solar above the tee. Adjust the valve closed slowly over a five minute period until the bubbles have stopped. If this valve is closed 50% or more, there may be other problems; consult the technical support line or a professional. The pool pump may be under sized, not supplying adequate lift and flow to fill the panels.

**Problem:** Inadequate heating.

**Solution:** Inadequate flow; see section on flow rate. Improper time clock setting; systems with a southern exposure should run from 9 AM until 5 PM. Heat loss at night; use a solar pool cover to insulate the pool surface against heat loss when night time



temperatures are below 60°F. Shade on the panels; remove obstruction or set time clock to run only when panels have sunlight on them. Under sized system; increase the number of panels.

## 11. Special Roof Requirements

Variations in the installation procedures are outlined below. Consult the technical support for other types of roof installations.

**Flat Tile or Barrel Tile Roofs:** The mounting hardware is attached to the tile using Tapcon Screws supplied with the kit (you must specify tile roof when ordering). This requires drilling a pilot hole in the tile before inserting the screw. Use a 3/16" masonry drill bit. DO NOT drill into the substrate below the tile; doing so will cause a roof leak. The mounting screws should be positioned 1" to 2" above the bottom edge of the tile. This will allow a space between the tile and the substrate due to the overlap in the tiles. On barrel tile roofs, try to lay out the panels so that the mounting holes fall on the tops of the barrel tile. This can be accomplished by using 6" rubber couplings where additional spacing is required; cut the coupling to the correct length.

**Cedar Shake Roofs:** If the cedar shakes are installed on top of a plywood surface, use a galvanized metal flashing (approximately 4"x4") under each shake where the mounting screw will penetrate. Center the flashing under the penetration location before installing the screw. Drill a pilot hole and apply a generous amount of sealant into the hole. If the cedar shakes are installed on fir strips, call for alternate installation method.

**Flat Built-up Gravel Roofs:** Use caution when installing on this type of roof. The preferred method is to have a roofing contractor install "roof curbs" where the mounting hardware will be installed.

**Open Beam Roofs:** Any ceiling with exposed beams must be checked to avoid the screw ends from penetrating into the interior space. Call for alternate installation method.

**Metal Roofs:** If the metal roof is installed on a plywood surface, you may proceed using the normal installation method. If the metal roof is installed on fir strips, the mounting hardware must penetrate into the fir strip to insure a good seal and to avoid bending the metal surface.

**Rubber or Asphalt Modified:** This type of roof is typically installed flat. Using a 2" to 2½" fender washer under the mounting hardware will provide additional mounting surface. Be sure to use a generous amount of sealant under the washer, between the washer and the mounting hardware, and on top of the mounting screw.

**Roof or Ground Mounted Rack Systems:** Rack systems can be made from pressure treated wood or aluminum. For roof mounted racks aluminum is preferred for its additional strength and longevity. Aluminum racks are available in a kit form. To order a kit, or to request a wood rack design specification sheet, call the technical support line.