

**INSTALLATION
OPERATION
MAINTENANCE
MANUAL
DBS DRAINBACK**



**Alternate Energy Technologies, LLC.
851 Energy Cove Court, Green Cove Springs, Florida 32043 USA
(800) 874-2190**

INTRODUCTION

“Conservation for today... Energy for tomorrow...”

Alternate Energy Technologies, LLC., (AET) would like to extend our congratulations on your purchase of the DBS Drainback System. Years of research and development, backed by critical engineering, has brought you the finest solar products you can buy. Please take time to read this booklet thoroughly. Each step is outlined completely and clarified by diagrams where necessary.

“The solar energy system described in this manual, when properly installed and maintained, meets the minimum standards established by the SRCC. This certification does not imply endorsement or warranty of this product by SRCC.”

The Drainback has been designed to be a complete solar appliance that incorporates ease of installation and maximum efficiency for years of trouble-free service. The system uses the sun’s energy to heat your water, reducing your electricity consumption. The system will pay for itself many times over the life of the system. All installations require a connection to your home water system. The system can be installed as a stand-alone system or as a preheat interface to an existing gas/electric water heating system. Only a qualified person or someone thoroughly familiar with standard plumbing and electrical practices should do the installation. If you have questions on the proper methods to make these connections, consult a qualified plumber or solar contractor for prescribed methods in your area. In most cases your installing solar contractor is familiar with the codes and their application. The codes are intended to protect the health, safety, and welfare of the public.

The system collects heat by circulating water between the reservoir, collectors and a heat exchanger immersed inside the lower portion of the storage tank. Since only thermally efficient pure water is used, maximum safety and performance is assured. The Drainback system is ideally suited to cold regions with many freezing days each year or areas with aggressive water conditions. Freeze protection is provided by draining the collector loop liquid back into the drainback reservoir when the system is not operating. The simplicity of the drainback method provides reliable operation that makes this system an asset to any home located in the colder climates.

YOUR DRAINBACK SYSTEM

Your Drainback system consists of a collector array, a drainback reservoir, a storage tank with an integrated heat exchanger, circulation pump/control combo, pre-engineered system.

<u>COMPONENT</u>	<u>MODEL #</u>
SYSTEM NUMBERS:	DBS-80-40, DBS-80-42, DBS-80-48, DBS-80-52, DBS-80-63, DBS-80-64, DBS-80-80, DBS-120-63, DBS-120-64, DBS-120-80, DBS-120-96
COLLECTOR(S):	MSC or AE Series collectors
PUMP/CONTROL:	009VTF5K Variable speed pump w/built-in controller - combo (includes flanges and sensors)
TANK:	TM-SS60-HE, TM-SS80-HE, or TM-SS120-HE Thermomiser Solar-Storage Tank (tank include T&P relief valve)
DRAINBACK RESERVOIR:	DBS-10 (reservoir includes sight glass & pressure relief valve)
DRAIN VALVE:	BD Series
ANTI-SCALD VALVE:	AM101C or 34A-104-1 (by others)
THERMOMETER(S):	T-60 (by others)

Job site conditions will require the installation contractor to supply some, or all of the following:

- plumbing connections
- piping and insulation
- valves between your own water system and the Drainback solar system

INSTALLATION INSTRUCTIONS

PRE-INSTALLATION CHECKLIST

Unlike other types of solar collectors, the AET solar collectors do not add a significant amount of weight to the roof. However, if the collectors are placed at a steeper pitch than the roof itself, the additional exposed flat surfaces could present extreme wind loading forces during sustained high winds. Check local codes for roof load requirements. The mounting hardware supplied with your Drainback system has been designed for specific wind loads, but only if adequate support structure is present with sufficiently strong structural members (such as engineered trusses). Most building permit offices may be able to help you with recommended roofing practices for your area.

Obtain all applicable permits. Structural members penetrated by the solar system components must meet local codes. The installer is to run the piping in such a way that the performance of any fire rated assembly is not reduced. This applies to the collector mounting as well as the installation of any other system components.

Inspect the roof. If it is in poor condition, it is advisable to replace all or part of the roof where the system will be attached.

Locate a roof area facing as close to due south as possible for the placement of the solar collectors. The plumbing runs must be planned in advance so that the shortest possible route between the storage tank and collector is made. Make sure you have no low points in the sloped horizontal pipe runs. This could trap water and in freezing weather cause the pipe to rupture.

NOTE: All collectors are to be mounted vertically, sloped in order to be completely void of fluid when drained, and oriented in such manner as described below under COLLECTOR LOCATION.

Make sure you have all the necessary plumbing materials, tools, and accessories before beginning work.

Wear gloves when handling the solar collectors! They get extremely hot when left exposed to the sun. The bright red plastic caps should be removed prior to placing the collectors on the roof otherwise they may get so hot that they melt in place. Also, never try to lift the collectors by the pipe nipples. These bend when hot and would damage the collector. You should have a tarp handy to keep the collectors covered during the entire installation process. This will prevent the collectors becoming too hot to handle as you make your final adjustments and connections.

Use only lead-free solder. Use of 50/50 lead solder is expressly prohibited. Use of galvanized steel, CPVC, PVC, PEX or any other type of plastic pipe is prohibited.

BASIC TOOLS AND MATERIALS

Electric Drill
Drill Index (w/ 1/2" and 3/4" Wood Bits)
Hack Saw
Tubing Cutter
Tin Snips
16' Tape Measure
24" Level
Flashlight
Extension Cord
Slip Joint Pliers
Needle Nose Pliers
Pipe Wrenches, 10" & 14"
Open End Wrenches, 9/16 & 7/16
Screw Driver 6" Flat Blade
Screw Driver 6" Philips
Wire Stripper or Knife
Wire Cutters
Adjustable Wrenches 8" & 10"

Torch and Striker
Putty Knife
High Temperature Pipe Joint Compound
Wire Nuts or Connectors
Miscellaneous Copper Pipe & Fittings (3/4")
Solder Flux
Emory Paper
Silicon Caulk and Roof Tar
1/2" I.D. and 3/4" I.D. Type M Copper Tubing
5/8" x 1/2" wall & 7/8" x 1/2" wall Armaflex or
Rubatex Insulation
Angle Iron
Threaded Rod, Nuts, & Washers
Stainless Screw Clamps
Thermal Adhesive
Aluminum Flashing Sheet
Black Latex Outdoor Paint

INSTALLATION

The Drainback storage tank module is as easy to install as any normal electric hot water heater. Any experienced plumber or solar contractor may accomplish this installation. In addition to the normal cold water in, and hot water out connections, there are only two other connections required.

If the Thermo-Miser Solar Water Heater is going to have a set temperature above 120° F you must use a rated anti-scald device to avoid severe burns or death from scalding temperature. The design and installation of the Thermo-Miser Solar Water Heating System should be done by qualified individuals. It is important that good design and installation practice be followed to assure that your system will operate properly. Failure to follow installation guidelines for your Thermo-Miser Solar Water Heater System could cause component failure and possible safety issues.

It is mandatory that all plumbing be done in accordance with all local and state codes or warranty will be void. It is also necessary on all mechanical connections to use both thread tape and pipe dope. The potable water piping is located on the side of your Thermo-Miser Solar Water Heater and marked Hot and Cold. It is recommended that unions or flexible copper connectors be used so heater can be easily serviced. Install a shut-off valve in the cold feed near the Solar Water Heater to isolate the tank for future service.

With solar tanks, the cold input from the pressurized supply line to the house (either city water or well water) must be fed into the tank inlet. This is marked "Cold Inlet" and is located on the bottom rear tank. A cold-water shutoff valve must be installed above this connection so that water flow may be completely stopped in the event of a leak, repair, or maintenance. There is a long plastic tube attached internally to this connection so that the incoming cold water is directed immediately to the bottom of the tank, and therefore does not mix and cool down the hot water. The hot water output to the house from the tank should be connected to the port labeled "Hot Outlet" on the top rear of the tank (see the schematics in the back of this manual). Provide clear access to the storage tank, pump, expansion tank, mixing valve, time clock and other key components. The components on the potable side of the system may require future service or maintenance, so it is recommended that the connections be made with brass unions. You must use copper and brass fittings in plumbing the solar storage tank and expansion tank. **The use of galvanized fittings, nipples, dielectric unions, dielectric nipples, CPVC, PVC or other plastic pipe is prohibited.**

All hot water lines should be insulated with at least ½" thick heat-resistant rubber tubing insulation such as Armstrong Armaflex.

COLLECTOR LOCATION

In most instances, the solar collectors can be attached to the roof using the standard mounting hardware provided with the Drainback system. Certain types of roofing will require special attention for proper mounting. For example, a clay tile or cement tile roof. Complete roofing attachment methods of solar collectors for these various types of roofs are beyond the scope of this manual. The manual will describe and illustrate some of these approved mounting techniques. A competent contractor should be used to ensure that all roof penetrations and attachment points are not a source of rainwater leakage later on. Standard plumbing roof jacks or solar industry copper flashings may be used for plumbing penetrations in most cases.

The collectors should be canted toward the inlet side to ensure they drain completely when the pump is not running.

CAUTION!

Solar collectors become very hot when in direct sunlight with no fluid being circulated through them. Extreme caution should be taken when standing near, or handling solar collectors in this state. The circulating pump becomes very hot when running. Do not touch before allowing sufficient time to cool down.

Proper location and orientation of solar collectors is important for maximum system efficiency. It is strongly recommended that collectors be mounted in the portrait orientation with the longest side traveling directly up the roofline, perpendicular to the roof peak. The best orientation is achieved when collectors are located on a south-

facing roof, with the collector facing as close to south as possible and tilted at an angle from horizontal equal to your latitude + 10°. Where aesthetics play an important role in the visual aspect of the installation, collector area can be increased accordingly and collectors mounted in the same plane with the roof, raised just inches above the roof surface to allow for shedding of rain and debris. Individual collectors can be coupled together, side-by-side, for multiple collector arrays.

The collectors should be unshaded for the middle six hours of the day in each month of the year and should be located as close to the storage tank as possible to minimize heat loss in the piping runs. Figure 1, on page 6, shows many alternatives for collector mounting. When roof mounting, place the collectors approximately three (3) feet from any peak, hip, valley or roof edge. This will make installation easier due to increased attic access and will aid in minimizing wind load forces.

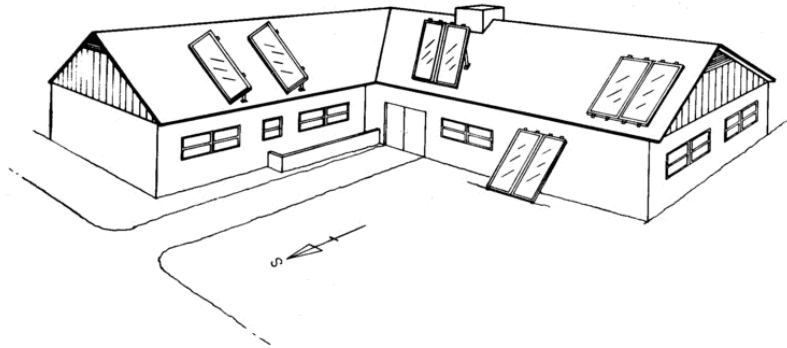

Figure 1

COLLECTOR ORIENTATION

Proper tilt angle for solar collectors is latitude plus 10°. This favors the winter sun because ambient temperatures are lower during the winter and collector efficiency suffers. This 10° additional tilt equalizes year round performance. Spacing can be determined from Table 1 below.

When collectors are mounted one behind the other, they are spaced apart so that in the morning and afternoon on December 21, when the sun is at its lowest altitude, the collectors will not shade each other and cause efficiency loss.

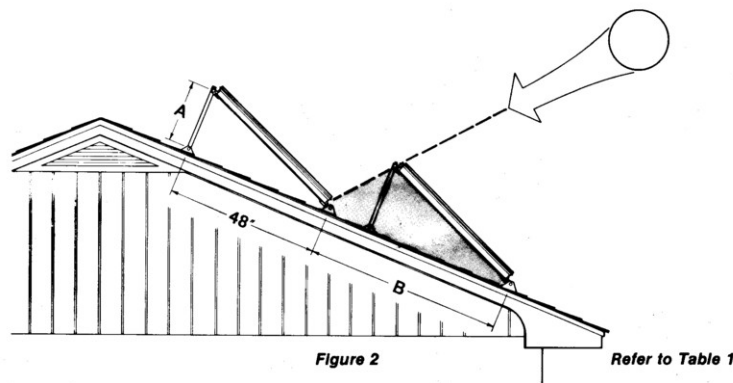

Figure 2

Refer to Table 1

LATITUDE		25° N		30° N		35° N		40° N		45° N		50° N	
COLLECTOR TILT		35°		40°		45°		50°		55°		60°	
		A	B	A	B	A	B	A	B	A	B	A	B
ROOF PITCH	FLAT	29	96	33	113	37	145	41	145	44	145	48	145
	5° 1/12	25	83	29	93	33	113	37	132	41	133	44	141
	9° 2/12	22	74	26	82	30	77	34	110	38	115	41	118
	14° 3/12	17	66	22	72	26	82	30	92	34	95	38	98
	18° 4/12	14	61	18	66	22	74	26	81	30	85	34	87
	23° 5/12	10	58	14	60	18	66	22	72	26	74	30	77
	27° 6/12	7	58	11	58	15	61	19	66	23	68	27	70
	30° 7/12	4	58	8	58	13	58	17	58	21	58	25	58
	34° 8/12	0	58	5	58	9	58	13	58	17	58	22	58
	37° 9/12	-2	58	3	58	7	58	11	58	15	58	19	58
	40° 10/12	-4	58	0	58	4	58	8	58	13	58	17	58
	43° 11/12	-7	58	-3	58	-2	58	6	58	10	58	14	58
	45° 12/12	-8	58	-4	58	0	58	4	58	8	58	13	58
VERTICAL		-44		-41		-37		-33		-29		-25	

Table: All Lengths in inches

MOUNTING HARDWARE

The system package includes a specially designed mounting hardware, to speed collector installation. This hardware consists of four hinge sets, four roof brackets, two rear struts, and bolts.

- After locating the mounting points from Table 1, the mounting bracket holes should be drilled.
- A heavy coating of sealant should be applied to the bottom of the flashing plate, which should fit flat against the roof. It is necessary for the plate to slide under the above shingles to insure proper drainage of water.
- The bottom of the roof bracket and the area around the threaded rod should also be thoroughly coated with tar sealant. When the bracket is set in place, alignment with the collector hinges is necessary before final tightening of the nuts. This should be completed before the sealant has time to set.
- The threaded rod is fastened through a 2' x 6" wood or 2" x 2" x 1/4" steel angle bracket under the roof as shown.

The rear struts should be cut and drilled to conform to Table 1. All bolts should be tightened securely. A stainless steel washer should be placed where the threaded rod passes through the aluminum bracket. It is very important that the penetrations through the roof be well sealed. It should be carefully checked that all bolts are coated with tar and that no leaks are possible.

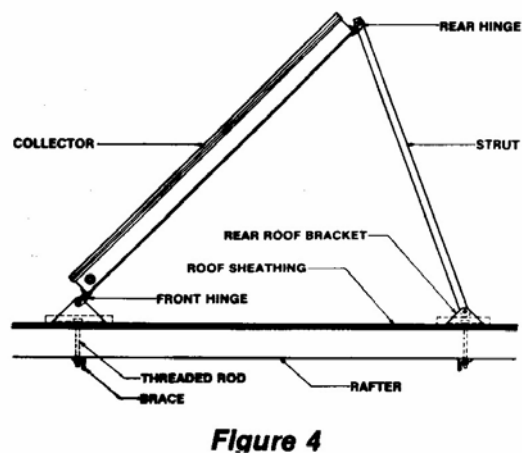
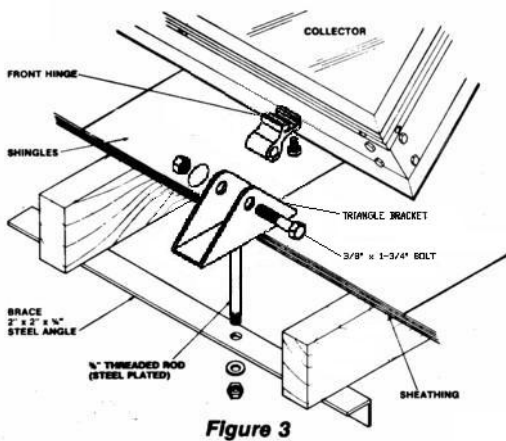

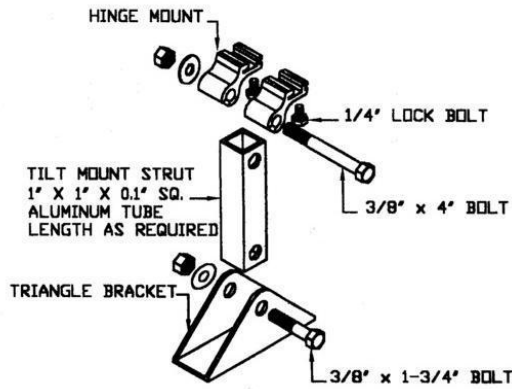

FIGURE 5

AE-Series			Center Line to Center Line (in.)		
Model	Size (ft)	Outside Box Dim. (in.)	AE-MH	AE-FM	AE-RM
AE-21	3 x 7	35.1875 x 85.1875	88.4375	88.9375	86.9375
AE-24	3 x 8	35.1875 x 97.1875	100.4375	100.9375	98.9375
AE-26	4 x 6.5	47.1875 x 77.1875	80.4375	80.9375	78.9375
AE-28	4 x 7	47.1875 x 85.1875	88.4375	88.9375	86.9375
AE-32	4 x 8	47.1875 x 97.1875	100.4375	100.9375	98.9375
AE-40	4 x 10	47.1875 x 121.1875	124.4375	124.9375	122.9375
MSC-Series			Center Line to Center Line (in.)		
Model	Size (ft)	Outside Box Dim. (in.)	MSC-MH	MSC-FRM	MSC-FM
MSC-21	3 x 7	35.8750 x 86.1250	90.5	87.375	37.125
MSC-24	3 x 8	35.8750 x 98.1250	102.5	99.375	37.125
MSC-26	4 x 6.5	47.8750 x 78.1250	82.5	79.375	49.125
MSC-28	4 x 7	47.8750 x 86.1250	90.5	87.375	49.125
MSC-32	4 x 8	47.8750 x 98.1250	102.5	99.375	49.125
MSC-40	4 x 10	47.8750 x 122.1250	126.5	123.375	49.125
ST-32	4 x 8	46.125 x 96.125	-	97.75	-

Table: Distance between centerlines of top and bottom mounts for all AE, MSC, ST series

MOUNTING THE COLLECTORS ON THE ROOF

For flush roof mount installation, AE-FM brackets are attached to the bottom of the collector and secured directly to the roof.

1. The 4 x AE-FM mounting brackets should be attached to the collector frame using the 1/4" lock-bolt on the bracket underside. Two brackets should be used at each end, at 6 to 12 inches from the corner of the collector. The 1/4" lock-bolt should be tightened snugly against the collector frame bottom.

2. The AE-FM are now attached directly to the roof with 3/8" SS mounting bolts (not supplied) extending all the way through the roof trusses or 3/8" lag bolts (not supplied) drilled directly into the roof trusses as shown. Thoroughly check the tightness of all bolts and screws.

STANDARD MOUNT (AE-MH)

The AE-MH hardware kit allows the greatest flexibility in collector elevation angle when mounting the collectors on tilt or flat roofs.

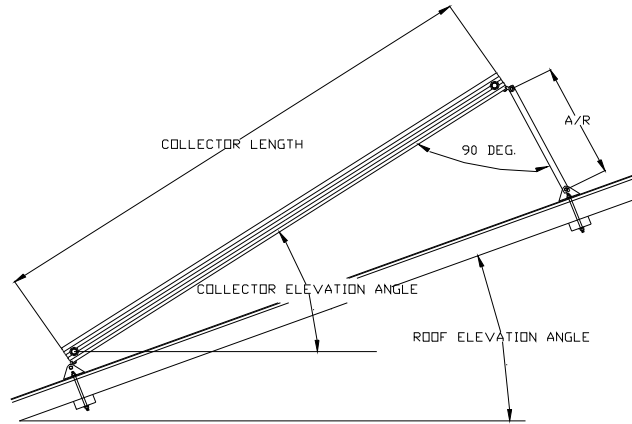

1. The 4 x AE-Clips should be attached to the collector frame uses the 1/4" lock-bolt on the bracket underside. Two brackets should be used at each end, at 6 to 12 inches from the corner of the collector. The 1/4" lock-bolt should be tightened snugly against the collector frame bottom.
2. The two front AE-Clips are attached to the two front Tilt Mount Triangle Roof Mounting Brackets, with two 3/8" x 1-3/4" SS bolts.
3. The two front Tilt Mount Triangle Roof Brackets are now attached to the roof with two 3/8" SS mounting bolts (not supplied) extending through the roof trusses, or two 3/8" lag bolts (not supplied) drilled directly into the roof trusses.
4. The two rear AE-Clips are attached to the rear Tilt Mount Triangle Roof Mounting Brackets via the Tilt Mounting Struts, using a 3/8" x 1-3/4" SS bolt at the bottom and a 3/8" x 4" SS bolt at the top of each strut.

Note: The Tilt mounting Struts should be cut to length to provide the required collector elevation angle as described in the following section.

COLLECTOR ELEVATION ANGLE

Ideally, the collector should be mounted at an elevation angle equal to the latitude of the collector location plus 10 degrees. Estimate your latitude based on your location in the United States.

If your roof elevation is within +/- 10° of the ideal elevation, then it is recommended that the collector be flush mounted with the roof. If not, then you will have to determine the length of the Tilt Mounting Struts required providing the ideal elevation for your roof and location as follows:

Calculating the Length of Strut Required:

- a. Determine the correct latitude column for your location.
- b. Now locate the correct row for your roof elevation angle.

- c. At the intersection of the column and row will be two strut lengths, in inches.
- d. Select the appropriate length based on the orientation of the collector on your roof. Use the long column if the collector is mounted portrait style. Use the short column if the collector is mounted landscape style.
- e. Cut the struts to length and drill a 7/16" hole at 3/4" from each end of the strut.
- f. Assemble the strut bottom to the triangle bracket with the 3/8" x 1-3/4" SS bolt supplied, and the strut top to the base of the collector using the two AE-Clips and the 3/8" x 4" SS bolt supplied. Secure the tilt mount triangle brackets directly to the roof using two 3/8" SS mounting bolts (not supplied) extending through the roof trusses, or two 3/8" SS lag bolts (not supplied) drilled directly into the roof trusses.
- g. Thoroughly check the tightness of all bolts and screws.

DETERMINING THE STRUT LENGTH REQUIRED

Method:

1. Determine the latitude of your location to the nearest 5°.
2. Locate the correct latitude column in the table.
3. Locate the correct roof pitch / elevation angle row in the table.
4. At the intersection of the row and column locate the strut lengths in inches.
5. Use long figure if the long side of your collector runs up the roof.
6. Use the short figure if the short side of your collector runs up the roof.
7. Cut the strut to the appropriate length.
8. Drill a 7/16" hole 3/4" from each end of the strut.
9. N/A = Ideal Collector Elevation not possible at this roof angle.
10. If length is in **BOLD** then heavier struts are required, see section 8 or contact AET.

Latitude		25°N		30°N		35°N		40°N		45°N		50°N	
Ideal Collector Tilt Angle		35		40		45		50		55		60	
Collector Orientation		Long	Short	Long	Short	Long	Short	Long	Short	Long	Short	Long	Short
Roof Pitch	Roof Angle												
Flat	0	59	25	70	30	84	36	100	43	120	51	145	62
1/12	5	48	21	59	25	70	30	84	36	100	43	120	51
2/12	9	41	18	50	22	61	26	73	31	87	37	104	44
3/12	14	32	14	41	18	50	22	61	26	73	31	87	37
4/12	18	26	11	34	15	43	18	52	22	63	27	76	32
5/12	23	18	8	26	11	34	15	43	18	52	22	63	27
6/12	27	12	5	19	8	27	12	36	15	45	19	55	23
7/12	30	7	3	15	6	23	10	31	13	39	17	48	21
8/12	34	1	1	9	4	16	7	24	10	32	14	41	18
9/12	37	N/A	N/A	4	2	12	5	19	8	27	12	36	15
10/12	40	N/A	N/A	0	0	7	3	15	6	23	10	31	13
11/12	43	N/A	N/A	N/A	N/A	3	1	10	4	18	8	26	11
12/12	45	N/A	N/A	N/A	N/A	0	0	7	3	15	6	23	10

Table: Determining the strut length required

There are three acceptable ways to secure the collector mounting brackets to the roof.

1. Spanner Mounting
2. Lag Bolt Mounting
3. J-Bolt Mounting

In spanner mounting after the brackets are positioned on the chalk line, a 3/8" hole is drilled between the rafters. Aluminum flashing is positioned over the hole where the top of the flashing is extended up under the shingle above the 3/8" hole and extends down over it. Caulk is applied between the flashing and the roof. The bracket is then positioned over the 3/8" hole using sealant between the bracket and the flashing. A piece of 3/8" all-thread is then inserted through the hole. A washer and nut secures the all-thread to the bracket (be sure the seal underneath the washer and on top of the nut). The all-thread rod should extend about 4" below the roof rafters. Drill a 3/8"

hole in a 2 x 4 and insert the all-thread rod through it. The 2 x 4 should span 2 rafters. With a washer and double nut secure the all-thread to the 2 x 4. Tighten down until the bracket is tightly secured to the roof. Be careful not to over-tighten and bell out the roof underneath the bracket.

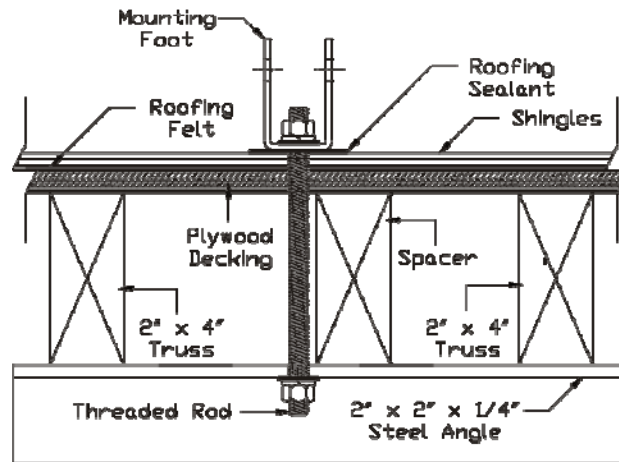

Figure: Spanner Mounting

In lag bolt mounting you must locate the center of the rafters along the top and bottom chalk lines. One method is to have one man on the roof and another in the attic. Using a hammer the man on the roof can tap the roof and determine where it is denser sounding. The roof man can drill a pilot hole while the attic man helps with distance corrections.

Then the attic man can call off the distance to the next rafter while the roof man drills corresponding pilot holes. Flashing the brackets is done as previously described. Secure the brackets to the roof using a 3/8" x 3" stainless lag screw, a flat washer, and a lock washer.

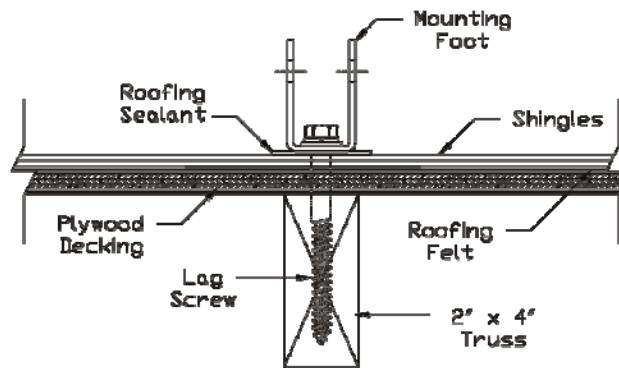

Figure: Lag Bolt Mounting

J-bolt mounting is done very similar to lag screw mounting except instead of drilling into the center of a rafter, a hole must be drilled directly beside a rafter. The size of the hole must be slightly larger than the bolt diameter. This is more easily accomplished if the attic man would drill a pilot hole through the roof along side the chosen rafter.

Fit the bolt through the mounting brackets and insert the bolt (J side first) through the hole in the roof. Work the J underneath the rafter. Pull the J-bolt snug against the rafter before tightening the nut. Use double nuts or lock-washers to securely fasten the mounting bracket to the J-bolt.

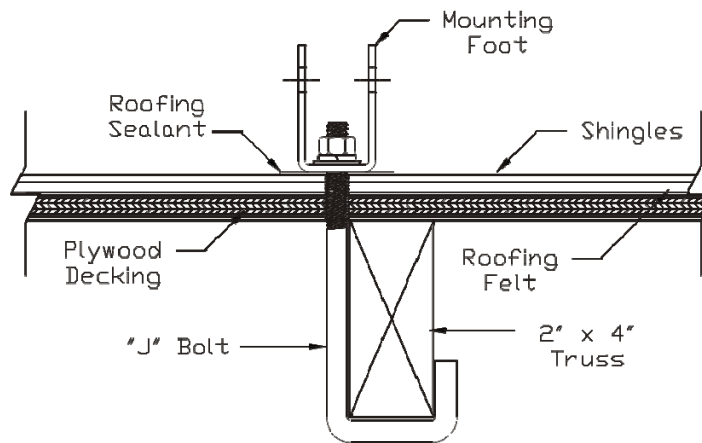

Figure: J-Bolt Mounting

PITCH PAN

The pitch pan is necessary any time standing water is encountered. The purpose is to provide an adequate seal around any penetration in the roof. Pitch pans are commonly used on flat roofs.

- The pitch pan is placed in the proper position and flat on the roof.
- Its flange is sealed with roofing felt and hot tar.
- The holes are sealed on the inside with roofing tar to a sufficient level to insure a permanent seal.

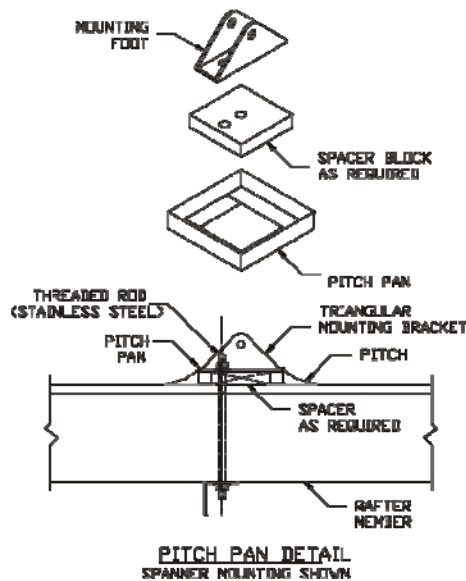

Figure: Pitch pan

ARRAY MOUNTING

Tile roofs are a little more difficult to mount solar collectors on but following this procedure will render a leak free installation.

The solar panels are mounted on two rails located at the top and bottom of the solar collectors. The collectors unistruts are secured to the rails using the AE rack mount hardware (AE-RM). The 1 5/8" Aluminum rails are anchored to the roof by using six or ten-inch stainless steel 3/8" hanger bolts. These bolts are lag screw on the bottom and 3/8 NPT thread on the top. A ten-foot length of unistrut should be anchored at three points, the middle and both ends.

Procedure:

- a) Cut 12" x 12" square pieces of lead flashing.
- b) Locate the roof rafters beneath the tile where the hanger bolts will be attached. Drill a 3/8" hole through the tile. Slide the 12" x 12" lead flashing under the tile located above the 3/8" hole, then drill through the lead flashing into the hole.
- c) Screw lag portion of the 3/8" hanger bolt into the rafter.
- d) Cut strips of the lead flashing about 1 1/2" long and wide enough that when you fold it into a tube is slightly larger in diameter as the hanger bolt.
- e) Using an acid core solder, weld the seam of the tube together.
- f) Slip this tube over the top of the hanger bolt protruding from the roof, then solder it to the 12" x 12" lead flashing.
- g) Thread down a stainless 3/8" nut to the bottom of the thread and seal the top of lead tube to the nut with a polybutylene caulk. Slip a 3/8" stainless washer on top of the nut.
- h) Place the 1 5/8" aluminum unistrut rail on the hanger bolt and secure with another 3/8" stainless washer and nut.

The rail is now secured, weather tight to the tile roof. Next, mount the AET solar collector to the rail using the AE rack mounts (AE-RM). See Figure below.

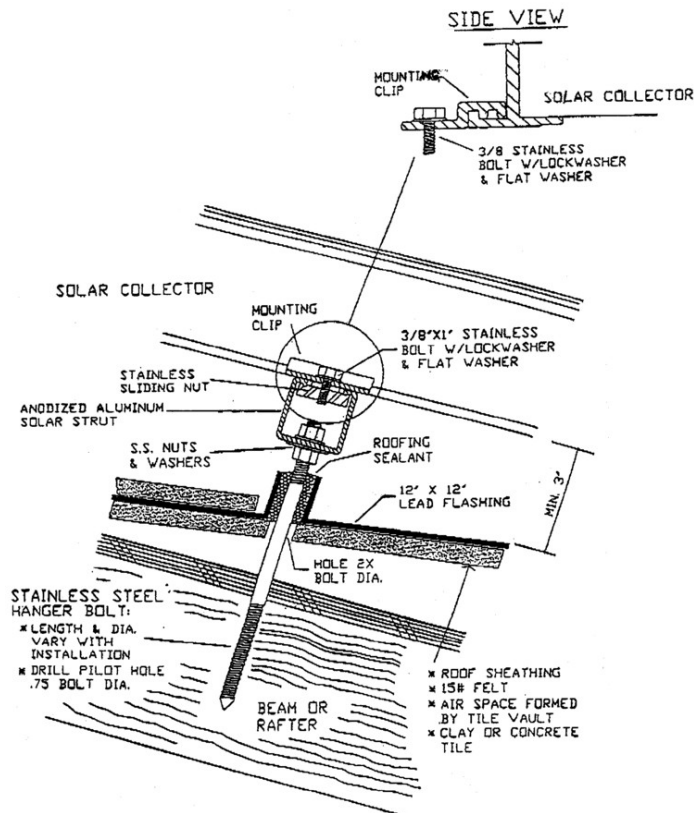

Figure: Rail mounting

COLLECTOR PIPING

All collectors and piping must be sloped a minimum of 3/8" per foot for drainage. All piping must drain without any fluid "traps." Soldered connections should be made with 95/5 solder.

The piping of the system should be considered before a final decision is made on how the collectors are mounted. Piping should be made of not less than 3/4" I.D. copper tube of the type meeting local codes, insulated with Armaflex or similar, and painted with exterior latex paint or wrapped with aluminum tape where exposed to ultraviolet radiation. Piping is supported using plumbers strap and should be installed in such a manner as to not crush the insulation.

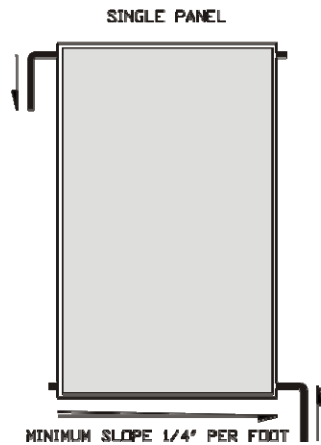

Figure: Single

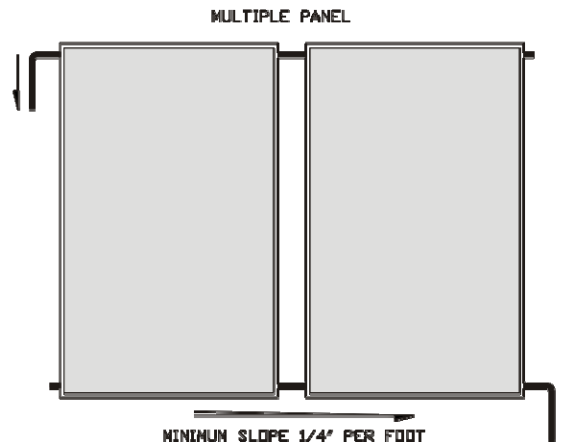

Figure: Multi

COLLECTOR PIPING DETAIL

The outlets of the collector are 3/4" copper nipples. They should be piped as shown below.

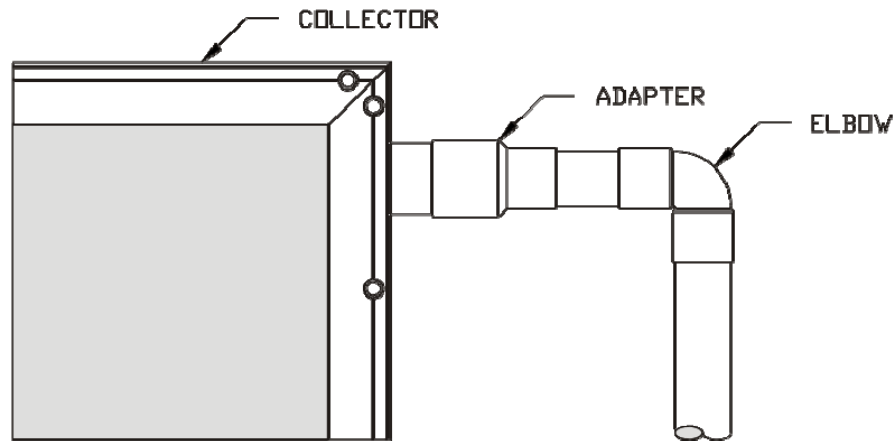

Figure: Copper nipples

PIPING THROUGH THE ROOF

Piping through the roof should be weatherproofed as shown in Figure below.

- a) One inch holes are drilled through the roof on the same plane as the supply and return header nipples. Do not drill the hole above the supply header of the collector. This will prevent the collector from draining. Placing the hole below the supply header is acceptable, but it is more aesthetic if it is located on the same plane. A copper flashing is placed around the hole with its base cemented to the roof and its upper edges slid under the adjoining shingle. Placing the flashing under the shingle is preferred.
- b) The copper tube supply and return line is then pushed up through the hole in the flashing.
- c) A "coolie cap" is then slid over the copper tube till it meets the flashing. After piping to the collectors is completed, the "coolie cap" is soldered to the copper tube.
- d) Polybutylene adhesive is placed on the top and bottom of the flashing, providing a weatherproof seal.
- e) The sensor wire is run through the return flashing which is equipped with a special wire chase (tube). Once the wire is in place, fill the wire chase with clear silicone caulk to weatherproof.

NOTE: The sensor wire should not be in direct contact with the return plumbing. Secure the sensor wire to the outside of the return pipe insulation.

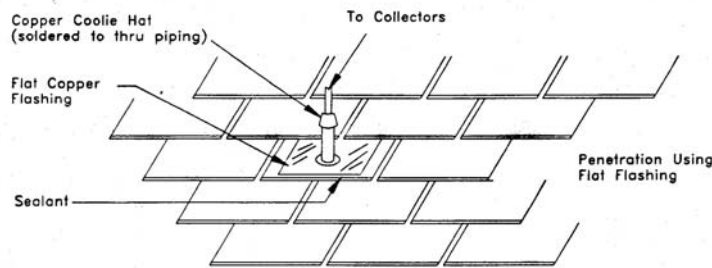

Figure: Piping through roof

STORAGE TANK PLACEMENT

To minimize expense and heat loss, the tank should be placed near the collectors and central to points of greatest water demand or adjacent to the existing tank when employed. It should be located in a warm spot, away from areas which would subject the drainback reservoir to freezing temperatures. It should be located with adequate ventilation, with a minimum of 6-8 inches of clearance and with ready access to controls and serviceable parts.

Provision should be made to prevent water damage in case of leakage. A catch pan with a minimum of ¾" drain line at least 2" in height may be installed and pitched for proper drainage. Electrical service of 115-120VAC should be available for the pump/control combo.

PLUMBING TO THE COLLECTORS

All pipe runs between the solar collectors must be solidly attached with proper clamping methods and properly insulated with 1/2" minimum Armstrong Armaflex, or equal rubber type insulation, pipe insulation (pipe insulation should be rated for 230°F). Insulate all hot water piping, as well as all of the exposed cold water piping at the entrance to the solar tank. Pipe insulation, exposed to the sun, should be painted with a latex based insulation paint to resist UV degradation.

A pressure and temperature relief valve must be installed on the storage tank.

A pressure relief valve must be installed on the drainback reservoir.

No air vent or vacuum breaker is necessary on the solar collector plumbing runs. The air gap at the top of the water in the drainback tank serves to break the siphoning action. This action is responsible for proper draining of the solar collectors when the solar circulation pump is shut off.

All plumbing runs between the tank and the solar collectors should be completely vertical when going up and down vertical wall surfaces. **All horizontal runs should be sloped at a pitch of 3/8" inch per foot back down towards the direction of the tank.** Care must be exercised in planning the installation so that no low points are created where water may become trapped. For example, a flat roof with a parapet wall should be penetrated rather than running pipes parallel to the roof surface then go up over the parapet wall before going down again. This would create a rather long horizontal low point in the pipe run where water gets trapped, and it would be unable to properly drain back into the drainback tank when the pumps shut off.

All plumbing connections to the solar panels should be made with copper pipe only. CVPC or PVC may not be attached to the solar collectors, as very high temperatures may be reached on hot summer days. AET does not recommend PEX installation in the collector loop.

Multiple collectors must always be connected in parallel as shown in the plumbing schematic.

Installation of an anti-scald valve is required. This is an automatic cold water mixer on the hot water side of the tank, which supplies hot water to the house. Refer to the system schematics at the end of this document for the installation location of this valve. Only ASSE 1016 and 1017 certified valves are to be used with this system. See the system parts list, on page 26 of this document, for the valve recommended for this system.

SENSOR INSTALLATION

The storage tank sensor should be mounted at the bottom of the storage tank. The hot collector sensor should be mounted on the solar collector header pipe as described below.

1. The hot collector temperature sensor should be mounted directly on the output or return collector header using a stainless steel band clamp as shown in the figure below.

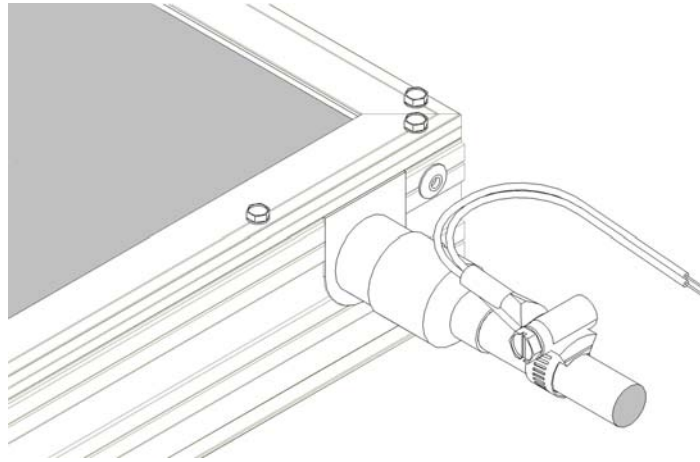

Figure: Installing the Collector Sensor

2. Run the sensor wire outside the pipe insulation to the collector.
3. Connect the collector sensor to the sensor wire using the Scotch lock connectors supplied.
4. Seal the connection using a silicon-based sealant.
5. All wire that is exposed to the sun should be protected from UV degradation using RBEF UV Finishing paint or equal. Also, properly secure the sensor wire runs.
6. Cover the sensor with pipe insulation to protect it from the elements.

SENSOR MOUNTING AT STORAGE TANK

On the storage tank, the heat sensor mounting located is behind the round cover just above the tank drain.

1. Remove the sensor mount cover to the tank.
2. Remove the cover insulation until the shell of the tank is visible.
3. Locate and remove the 5/16" nut from the stud and place the sensor on the stud. Secure it with the nut.
4. Cut a small slit in the sensor mount cover and feed the sensor wire (from the controller) through it.
5. Connect the sensor wire to the sensor pigtails and secure with wire nuts or crimp connectors. Note: it does not matter which wire is attached to the other.
6. Replace the insulation and sensor wire cover.

ELECTRICAL INSTALLATION

All connections should be made in accordance with local electrical codes. A qualified electrician or contractor is required to install a 115-120VAC duplex receptacle adjacent to the solar storage tank. This receptacle is used to supply power to the pump/control combo. When installed as a preheat system to and existing gas/electric water heater, it is not necessary to connect the backup element on the solar storage tank.

WARNING: *The solar storage tank does not require electrical connection when this system is installed as a preheat to an existing water heater.*

DRAINBACK DIFFERENTIAL TEMPERATURE CONTROLLER

See instructions provided with controller in box for proper installation.
 Specifications for controller:

Operating Voltage	105 to 125 vac, 60 Hertz
Control Relay Contact Rating	One third HP inductive load.
Setpoint Temperature Difference	10°F (+1°F) for Storage Sensor
Setpoint Temperature Differential	5°F (+1°F) for Storage Sensor
Maximum Sensor Temperature	300°F
High Limit Setting	Variable – see controller instructions

It is recommended that the controller high temperature limit be set at 140°F.

The following is for Taco Series Pump/Control setup. For other control setups, refer to the manufacture.

The 00-VT operates the collector pump to transfer heat between the collector and a storage tank based on a setpoint temperature difference (delta T) and setpoint temperature difference differential. The setpoint temperature difference is fixed at 10°F and the setpoint temperature difference differential is fixed at 5°F.

For delta T operation, the collector pump operates between the minimum variable speed output and full speed. Once the actual temperature difference rises to at least 10°F, the collector pump turns on at full speed for 10 seconds. After 10 seconds, the collector pump operates to maintain the 10°F setpoint target temperature difference. As the actual temperature difference increases, the variable speed output is increased. As the actual temperature difference decreases, the variable speed output is decreased. Once the actual temperature difference falls to the 5°F setpoint target temperature difference differential, the collector pump is turned off.

Powering the control

Insert the line voltage wires through the knockout of the enclosure and connect the live wire to the H terminal and the neutral wire to the N terminal on the PC Board. (see Figure 17) Ensure that no power is present during this process.

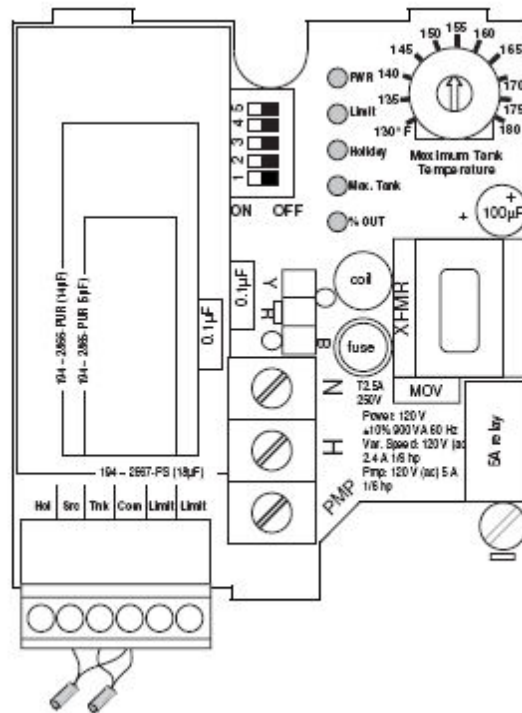

Figure 17

Refer to the manufacturer's instruction sheet for specific operations and limitations.

OPERATION INSTRUCTIONS

THEORY OF OPERATION

As the sun comes up in the morning, and starts to shine on the solar collectors, the collectors will begin to heat up. This system has a pump/control combo that senses temperature differences between two sensors, one at the outlet of the solar collector and one near the lower one-third of the storage tank. When the temperature at the collector sensor is about 10° F warmer than the temperature at the tank sensor, the controller turns on the pumps. When the temperature difference drops to about 5° F, the pump is turned off. In this way, the water always gains heat from the collector when the pump operates. The solar installer manually sets the differential temperature of the controller at the time of the system installation. The pumps are very quiet, so you may not notice when they are on and when they are off.

The system collects heat by circulating the water in the collector loop through the collectors, the drainback reservoir and a heat exchanger on the storage tank. When the pumps turn on, the water in the collector loop is circulated through the solar collectors, where it is heated. The return water from the solar collectors passes through the drainback tank and to the heat exchanger. The heat exchanger gives up the collected heat to the water in the storage tank. The now cooler water is returned to the collectors to continue to collect heat. When there is no longer a marked difference between the temperature at the solar collector and at the solar storage tank (4° F) the controller automatically turns the pumps off – since there is no heat to be gained. This process is repeated continually throughout the day, so that by the end of the day, the water in the storage tank is hot. This is all done automatically and requires no interaction on the part of the system owner.

Drainback systems provide a fail-safe method of ensuring that collectors and collector loop piping never freeze by removing all water from the collectors and collector piping loop when the system is not collecting heat. Freeze protection is provided when the system is in the drain mode. Water in the collectors and exposed piping drains into the insulated drain-back reservoir tank each time the pump shuts off. A slight tilt of the collectors is required in order to allow complete drainage. A sight glass attached to the drain-back reservoir tank shows when the reservoir tank is full and the collectors have been drained. For this reason the Drainback system is protected from freeze damage at all temperatures.

Note: The collector and collector plumbing should be sloped back toward the drainback reservoir at 3/8" per foot minimum to allow the system to drain.

All solar systems will have a backup source of heating. A common backup source is gas or electric water heater. Backup sources are used because on some days, when it is very cloudy, the solar contribution will be very small. On days when there is plenty of sun, and the sun is doing the work of heating the water automatically, the resulting high water temperature in the tank will keep the internal hot water heater thermostat from turning on the gas or electric heat, thus saving fuel and money.

DRAINBACK SYSTEM COMPONENTS

This system is comprised to the following components:

- Solar Collector(s) – (AE or MSC Series Collectors)
- One circulation pump/control combo with flange set
- One heat exchanger storage tank w/ T&P relief valve - (60, 80 or 120 gal)
- One drainback reservoir w/ pressure relief valve- (10 gal)
- One fill/drain valve
- One mixing valve (by others)
- Two thermometers (by others)

THE SOLAR COLLECTORS

The collector array consists of solar collectors of sufficient size to meet the design criteria for your household needs and geographic area, plus a set of 4 mounting brackets for each solar collector. The collectors are the Alternate Energy Technologies, AE or MSC series, using Thermafin absorbers with Selective Crystal Clear Black coating. The Crystal Clear Black surface has been proven to withstand very high temperatures for long periods of time and will not flake or chip. It is a revolutionary coating, which is actually a crystalline structure that is "grown" on the surface of the copper plating material. Crystal Clear Black coating is a leading edge technology that allows the maximum amount of solar energy to be absorbed at the lowest light level and virtually eliminates the amount of energy reflected to the sky.

The absorber plate within the collector is made of Thermafin risers. Using a high frequency forge welded molecular bond between copper tube and copper fin to form the risers that make up the absorber plate. Thermafin is designed to conduct the maximum amount of heat absorbed to the fluid that passes through the tube and returns to the storage tank. Unlike other methods, that solder or braze the tube and fin, Thermafin has only copper to conduct the heat and is therefore the most efficient product available.

The glass on the solar collector is a low iron tempered glass of exceptional clarity. This means that sunlight coming into the collector loses very little energy and transforms almost all of the light into heat. The tempered glass is very strong and resists damage that ordinary window glass could never withstand. A high-density foam material is used to provide insulation and minimize heat loss in cold weather. All copper piping is externally sealed with high temperature silicone grommets. All of this ensures that the maximum heat energy is transferred to the water, which is stored for use as needed.

The aluminum frame of the collector consists of extruded aluminum, with an integral quick lock-mounting rail for ease of installation with our patented "Quick lock" mounting hardware. The mounting brackets come in a set of 4 per solar panel, and all hardware is included except for the actual bolt used to attach to the roof or mounting surface. All fasteners and bolts are made of high quality and long lasting stainless steel.

THE CIRCULATION PUMP/CONTROL COMBO

The collector loop pump is selected for its head pumping characteristics. This pump is very quiet, efficient, and reliable. The collector loop pump is located below the drainback reservoir so that it has water pushing into the suction side of the pump from above, and therefore will never run dry. If this pump needs to be replaced all moving parts are contained inside a replaceable cartridge. The outer pump body may be removed by unbolting the pump flanges, and the inner cartridge may be replaced without having to disturb any of the plumbing.

The pump includes an on-board differential controller (and its accompanying sensors) used to activate the pumps. The controller is preset by the manufacturer to turn the pumps on and off at a specific temperature – usually on at 10°F difference between the sensor at the water heater and the sensor at the collector, and off at a 5°F difference.

THE STORAGE TANK

The water storage tank used in this system is of stainless steel construction and contains a heat exchanger for the solar interface. The water storage tank, stores the heat energy generated by the solar system. As the pumps circulate the fluids throughout the system, the fluids become hot and this heat energy is transferred to the water in the storage tank via the heat exchanger. This large volume of heated water used as the hot water source for the fixtures in the building/residence.

DRAINBACK RESEVOIR

The Drainback reservoir is a very high quality, well-insulated, hot water storage/transfer device. Potable water, in the storage tank, never comes in contact with the fluid in the collectors. The heated water, from the solar collectors, is directed through the heat exchanger encompassing or immersed in the storage tank. The heat exchanger transfers heat from the collector loop fluid to the potable water in the storage tank.

The backup water heating source is provided by a thermostatically controlled 4500 watt element in the storage tank. Refer to the water heater's installation manual for specific installation/electrical requirements.

SYSTEM VALVES

The Drainback system is equipped with several valves required for maintenance and protection of person and property. A temperature and pressure relief valve, on the storage tank, insures that excessive temperatures and system pressure is adequately relieved as needed. A pressure relief valve, on the collector loop, insures the collector loop does not exceed the design pressure of the system. A fill/drain valve is used when performing system maintenance or repair. An anti-scald valve is required to insure that the water delivered to the fixtures does not exceed scalding temperatures. (The anti-scald valve is to be provided by the installer).

FREEZE PROTECTION

The homeowner is not required to perform any actions to prevent freeze damage to the collectors. The system is only circulating when the collectors are hotter than the storage. In freezing conditions this is not the case, therefore there is no circulation and the water has drained from the collectors into the reservoir.

This system has a freeze tolerance limit of -60°F (60° below zero F), ambient air temperature. When conditions such as these are present, during prime daylight hours, power to the controller should be disconnected by unplugging the power cord to the controller.

“Freeze tolerance limits are based upon an assumed set of environmental conditions. Extended periods of cold weather, including ambient air temperatures above the specified limit, may cause freezing in exposed parts of the system. It is the owner’s responsibility to protect the system in accordance with the Supplier’s instructions if the air temperature is anticipated to approach the specified freeze tolerance limit.”

OPERATING INDICATORS

Thermometers (provided by the installer) are installed on the feed/return lines, to/from the collectors to allow the system owner to easily identify the when the solar collectors are working properly. The return line from the collectors should be hotter than the feed line. A properly installed solar system should provide a temperature differential between 8° and 20°F.

The Drainback system also uses a sight glass, on the drainback reservoir, as an indicator that the system is working. As the pumps are energized, the fluid level across the sight glass falls, thus indicating that the fluid is being removed from the drainback reservoir. As the pumps are de-energized, the fluid level across the sight glass rises, thus indicating the fluid in the solar loop is returning (draining) back into the reservoir.

FILLING THE DRAINBACK RESERVOIR

Note: Do not use Reverse-Osmosis or De-ionized water in the collector loop

1. Attach hose to fill valve “A”
2. Open fill valve “A” and the PR-30 relief valve (the pressure relief valve on the drainback reservoir)
3. Slowly fill the drainback reservoir to the top of the reservoir sight glass
4. Shut off fill valve “A” and close the PR-30
5. Remove fill hose

(Note: If replenishing water during periodic maintenance, make sure the controller is unplugged.)

START-UP PROCEDURE

1. Insure the system is filled, as directed above
2. Turn on pump and let run for 5 minutes
3. Check for leaks at collectors and in attic.
4. Switch controller to the automatic mode.

Once the complete system is in place, plumbed, and charged with heat transfer fluid, the final act to commission the Drainback system is to simply plug the controller line cord into a standard 115 VAC wall outlet. If the sun is shining and the tank is cool, the pump should turn on and the water should circulate.

SERVICE / MAINTENANCE PROCEDURES

SHUT DOWN PROCEDURE

To shut down the Drainback system, simply unplug the differential controller. The pump will stop and the water will drain out of the collectors and into the drainback reservoir.

CAUTION!

Never open the pressure relief while the system is in operation or hot water is present.
Allow to cool prior to opening.

DRAINING THE DRAINBACK RESERVOIR

1. Unplug the controller and wait until all water returns into the reservoir
2. Attach hose to fill valve "A"
3. Open the pressure relief valve (see the caution statement above)
4. Open fill valve "A" (pressure relief MUST be open first)
5. Allow the system to drain completely
6. Close fill valve "A" and the pressure relief valve
7. Remove the drain hose

TROUBLESHOOTING GUIDE

The homeowner will know that the solar system is operating if the pump is running and the water level in the sight glass is low. This indicates that the pump has pumped the water from the reservoir through the collectors.

Problems with systems usually fall under two categories: system leaks or lack of sufficient solar heated water.

LEAKS

If leaks exist, the system should be shut down for repair. Make sure the electrical circuit to the controller is unplugged. Close off the cold water inlet to isolate the solar system, until a suitable repair can be made.

There is a possibility that what may appear to be leaks may be condensation on the pipes. Also, water escaping from the T&P relief valve, on the water heater, may be an indication of proper function as they are designed to vent off excess temperature and pressure. Discharge from the T&P relief valve can happen, but it should be checked if it happens frequently.

INSUFFICIENT HOT WATER

If insufficient hot water is available, a system malfunction may not be indicated. A low amount of solar radiation or heavy water demand can be the cause. If no excessive demands are put on the system and ample solar radiation is available, the system should operate properly. The pump should run each sunny day until a full supply of hot water is stored. If the pump does not run, there is a problem on the electrical end of the system. Either, the pump, controller, or sensors may be malfunctioning. The controller can be bypassed by running a power cable directly to the pump and checking its function separate from the control system. Make sure that the problem is not a blown fuse or a tripped breaker. If the pump runs normally when powered externally, the control circuit is the problem area.

Differential controllers use thermistor sensors to determine modes of operation. A controller tester is available from AET for checking differential function. Check sensor wiring. If no faulty wiring can be discovered, replace sensors.

If the pump is running all the time, even when the collectors are cool, then the storage sensor or collector sensor may be open. It is also possible that the sensor wire itself is at fault. To check this, service personnel should test the continuity with an ohm meter. Be sure to disconnect the sensor when performing this test. Test the wire with both ends open, then retest after twisting the 2 sensor wires together at one end. The system can be set on a timer or switched on manually until the controller is properly functioning.

SYSTEM TROUBLESHOOTING AND OPERATIONAL CHECK

The system can be checked to determine that it is operating by noting the temperature difference between the collector feed and collector return lines. The return line should be hotter than the feed line. In addition, the owner should periodically check the drainback reservoir sight glass to make sure that there is sufficient water in the drainback reservoir.

The table below lists some of the possible problems, their cause, and their remedy. System owners are advised to contact the installer whenever a remedy requires some type of in-depth interaction with the solar system.

PROBLEM	POSSIBLE CAUSE	REMEDY
Insufficient Hot Water	Insufficient Solar Energy Back up source Excessive hot water consumption	Check system size, location & orientation Check / Replace Reduce consumption
Pump does not start	Controller switch in "Off" position Controller unplugged or blown fuse Defective sensor	Turn to "Auto" Return power to controller or replace fuse Replace sensor
Pump runs continuously	Controller in "On" position Defective sensor	Turn to "Auto" Replace sensor
Pump operates but no fluid Flows through the collectors	Flow tubes clogged Loss of fluid in drainback system	Flush collector tubing Cool system, locate air leak, refill properly
No water	Isolation Valve closed	Open valve
System leaks	Pipe burst due to freezing or defective joint Defective seals or piping	Repair or replace Check pipe insulation Repair or replace
System does not drain	Collector installed at incorrect angle Piping insufficiently sloped for draining	Change so draining can occur Check and ensure that piping slopes 3/8" per foot

OTHER PROBLEMS

A noisy pump is an indication of worn bearings, obstruction or loss of prime. As a rule of thumb, an 8-12° temperature gain should be expected across a collector, in bright sun, at the proper flow rate.

MAINTENANCE

DRAINBACK MAINTENANCE

Maintenance of a drainback system is minimal. The storage tank should be partially drained every 6 months to allow minerals to be removed preventing scale build up (this is recommended for all water heaters).

The collector glass should be kept clean for best system performance. Rain water will usually suffice, but a garden hose can be used during dry, dusty weather.

ROUTINE MAINTENANCE

In areas of infrequent rain the collector glazing should be visually inspected on a periodic basis (once a quarter) and cleaned with a hose if necessary.

The water level used as the heat transfer fluid in the drainback reservoir should be checked bi-annually. With the system off, make sure that the water level in the sight glass at the drainback reservoir is to the top of the sight glass. If not, follow the instructions in “Filling the Drainback Reservoir”.

The storage tank should be flushed on an annual or bi-annual basis following the manufacturer's recommendations.

Exterior pipe insulation should be treated as required with an exterior UV inhibitor paint. Contact your authorized AET Dealer if you feel insulation needs re-coating or replacement.

NON-ROUTINE MAINTENANCE / TROUBLESHOOTING

In case of a leak in the collector system, first attempt to identify the source of the leak, then unplug the controller. Since the indirect Drainback system is already isolated from the solar storage tank via the heat exchanger, no valves need to be operated. If the leak is in the collector contact your installation contractor listed below or AET direct for instructions on how to repair or replace the absorber plate.

For leaks in the potable water system or the solar storage tank, close off the cold water inlet to isolate the solar system, until a suitable repair can be made.

VACATION PROCEDURES

If no hot water is to be used for some time, unplug the controller to allow the system to drain. To re-energize the system, simply plug the controller back into the power receptacle.

SYSTEM PARTS LISTING

<u>COMPONENT</u>	<u>MANUFACTURER</u>	<u>MODEL</u>
Solar Collector(s)	Alternate Energy Technologies, LLC	AE or MSC Series
Pump/Control Combo	TACO, Inc.	009-VTF5K
Water Storage Tank	Heat Transfer Products	TM-SS60-HE, TM-SS80-HE, TM-SS120-HE
Drainback Reservoir	Heat Transfer Products	DBS-10
Drain Valve	Watts Regulator	BD Series
Anti-Scald Valve	Honeywell – Sparcomix	AM-1-Series (recommended)
Thermostat(s)	Honeywell	GT162 (recommended)

ESTIMATED COMPONENT LIFE

When installed and maintained as directed in this manual, one can expect many years of trouble-free service from this system. All components in this system are subject to the conditions of the installation. In locations where hard water is present, mineral deposits can prematurely foul-out the design life of these components. Periodic maintenance is required to insure that these components are well protected from such damage.

The solar collectors used in this system have a design life of 30+ years. Water storage tanks are designed for 12-20 years of use. The lesser components, such as pumps and valves are designed for 5+ years, however, are more likely to foul, as described above, if not maintained properly.

REPLACING THE TANK ELEMENT

The electric element installed in this water heater is specifically designed with a brass base and stainless steel – standard glass lined elements will not work in this tank and must not be used – only use an AET approved element. Call AET for a replacement element at 800-874-2190 (Ref: P/N WH-4500EIS)

WARRANTIES AND DISCLAIMERS

Please note that we specifically exclude any warranty for, or liability from, acts of nature, including freeze damage and shading of the collectors by future growth.

Warranty periods for all the major components are given below:

<u>Item</u>	<u>Part#</u>	<u>Period</u>
Collector(s)	AE or MSC Series	12years
Pump/Controller	009-VTF5K	3 years
Storage Tank	TM-SS60-HE, TM-SS80-HE, TM-SS120-HE	10years
Drainback Tank	DBS-10	10 years
Valves	various	1 year

All parts are available from your authorized agent or from AET direct.

FLUID QUALITY

This system uses water as a heat transfer fluid media in the solar loop. ***Reverse-Osmosis, or De-ionized water is considered corrosive, and shall not be used in the solar loop.***

“No other fluid shall be used that would change the original classification of this system. Unauthorized alterations to this system could result in a hazardous health condition.”

HAZARDS

Solar collectors become very hot when in direct sun with no fluid being circulated through them. Extreme caution should be taken when standing near, or handling solar collectors in this state.

The circulating pumps become very hot when running. Always allow at least 30 minutes for the pump to cool down before touching the pump.

Relief valves may discharge fluids at high temperature and/or pressure.

FLUID SAFETY LABELING

Included with your Drainback system is a set of labels which describe the component function. These labels are necessary to alert the owner of potential hazards. These labels are affixed by string/wire tie (on valves) and/or “peel-and-stick” (on pipe insulation). All labeling must be in place at final inspection. Label examples are as shown on the following page.

FLUID SAFETY LABELING:

Valve “A” – this label is affixed to the system fill/drain valve at the lowest point in the solar plumbing loop.

The heat transfer fluid is introduced here. When properly charged, the fluid level should be approximately 1/4” from the top of the sight glass, on the drainback reservoir.

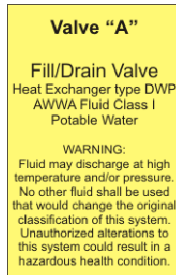

System Drain – this label is affixed to the tank drain valve at the base of the water storage tank.

This valve is to be used only as directed in the water storage tank owner’s manual or as directed in this manual. Power should be disconnected, at the circuit breaker, prior to service.

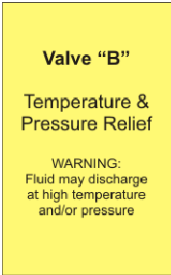
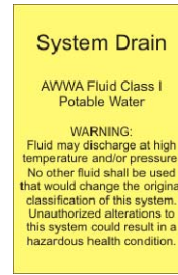

Valve “B” – this label is affixed to the temperature and pressure relief valve on top of the water storage tank.

The valve is preset to open and discharge if either a high pressure or high temperature situation occur in the water storage tank.

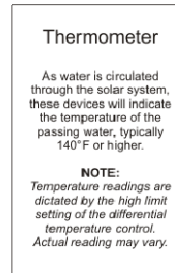

Thermometer – this label is affixed to the temperature gauges on the collector feed/return lines.

The gauge will display the temperature of the HTF to/from the collector. During system operation, the collector return line temp should read approximately 8° or more above the outside ambient air temperature.

Valve “C” – this label is affixed to the pressure relief valve on the drainback reservoir.

This valve is normally closed and may open and discharge if high pressure occurs in the collector plumbing loop.

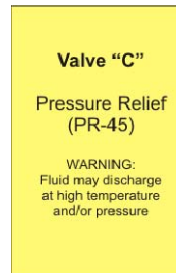

Sight Glass – this label is affixed to the base of the sight glass on the drainback tank.

The sight glass is used in conjunction with the temperature gauge as a means by which an observer can easily identify that the system is operating properly.

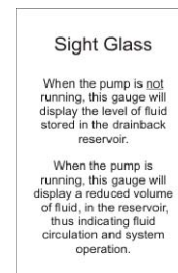

Valve “D” - this label is affixed to the cold water supply, “shut-off” valve.

This valve is normally open and should **only** be closed when maintenance is performed on the system. Power should be disconnected, at the circuit breaker, prior to service.



Freeze Protection – this label is affixed to the collector return line at the base of the drainback tank.

Manual intervention is required as a secondary precaution to protect components from freeze damage, when air temperatures fall below -60° F (-51.1°C).

Valve “E” – the label is affixed to the anti-scald valve.

This valve is used to limit the temperature of the water to the fixtures in the dwelling to prevent scalding.

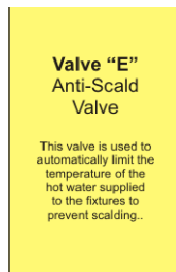

WARNING / HOT – labels are affixed to the collector return line at the drainback tank, the hot water supply line from the water storage tank and on all system components that could present a safety hazard due to high temperatures.



NOTE: The fluid safety labeling, as described above, is intended as a means of identification for the homeowner and/or service personnel. Removal of these labels could result in personal injury.